

LED Panel Light

Features

- Color: full color
- Enclosure material: Al6063, PMMA.
- Power factor > 0.95
- Beam angle: 105 Degree
- Saving energy: 50%
- Lifespan more than 40,000Hrs
- Working voltage: 24VDC
- LED Source: 5050 SMD LED, 168 PCS.
- Reflector: milk color PMMA
- No UV, no IR
- Standard warranty: 3 years
- Safety standard: RoHS, CE, UL pending

SC-PSF24FE3012

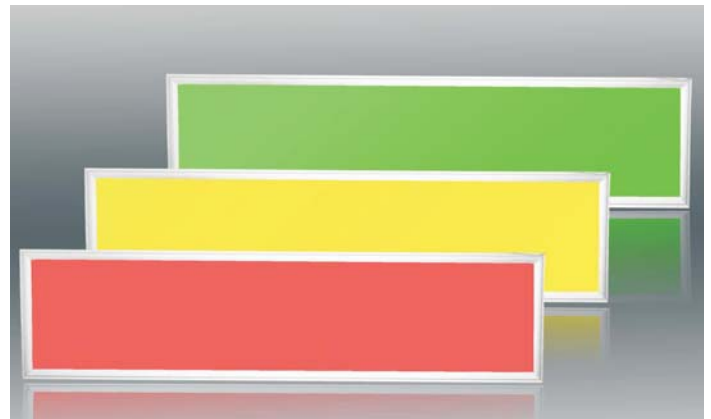

(optional)



Applications

- Hotels
- Conference / Meeting rooms
- Factories & Offices
- Commercial Purposes.
- Residential / Institution Buildings
- Schools, Colleges & Universities
- Hospitals
- Places where energy saving and high color rendering index lighting are needed.



Dimensions (Unit: mm/inch)

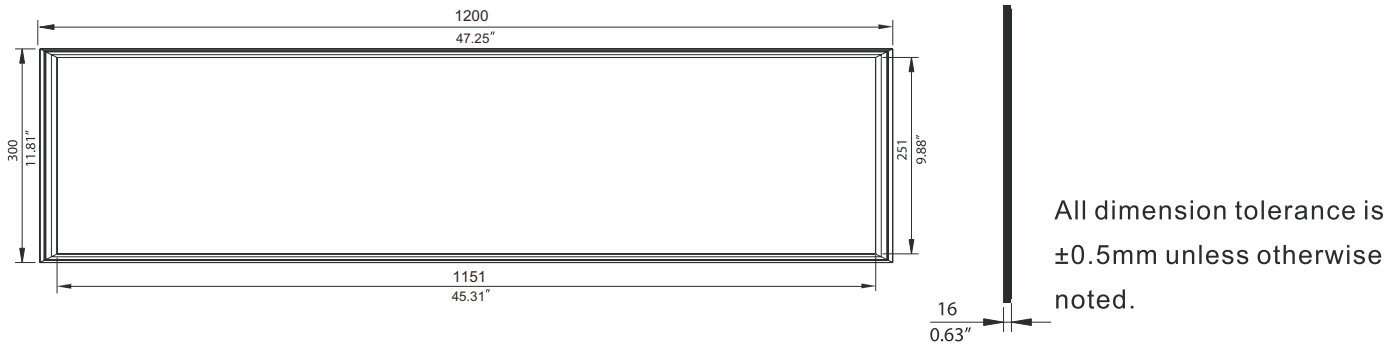

Specifications

Model #	Color	LED Type(PCS)	CCT	Rated Power Consumption	CRI	Luminous Flux	Working Voltage	Beam Angle	Weight
SC-PSF24FE3012	Full Colors	SMD 5050(168PCS)	\	42W	\	\	24 Vdc	105°	6.5kg

Packing Specification

1. All dimension units are millimeter.
2. 4pcs inner box in one carton.

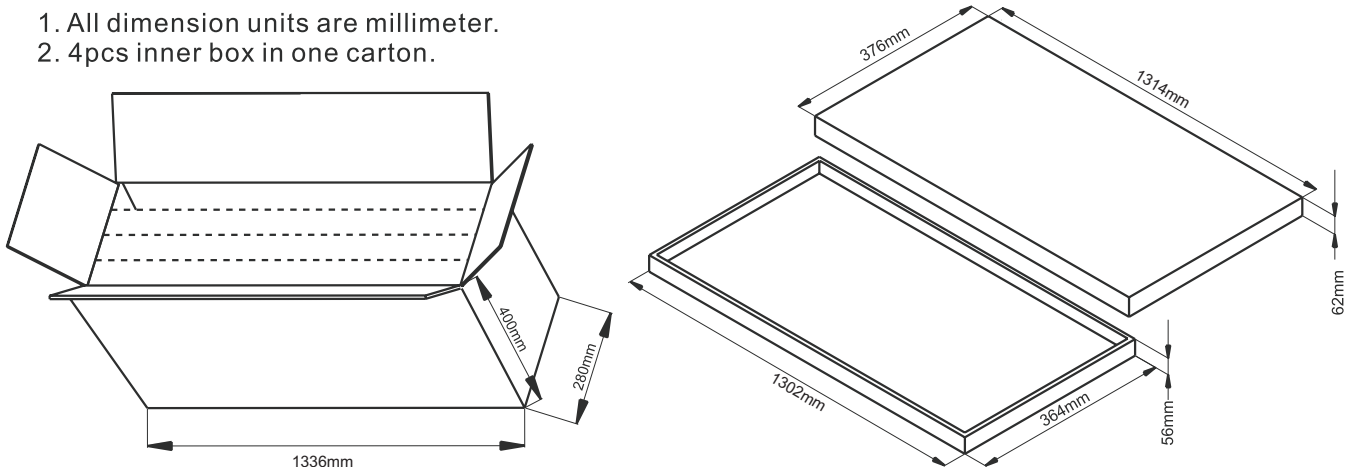

Electrical Connection

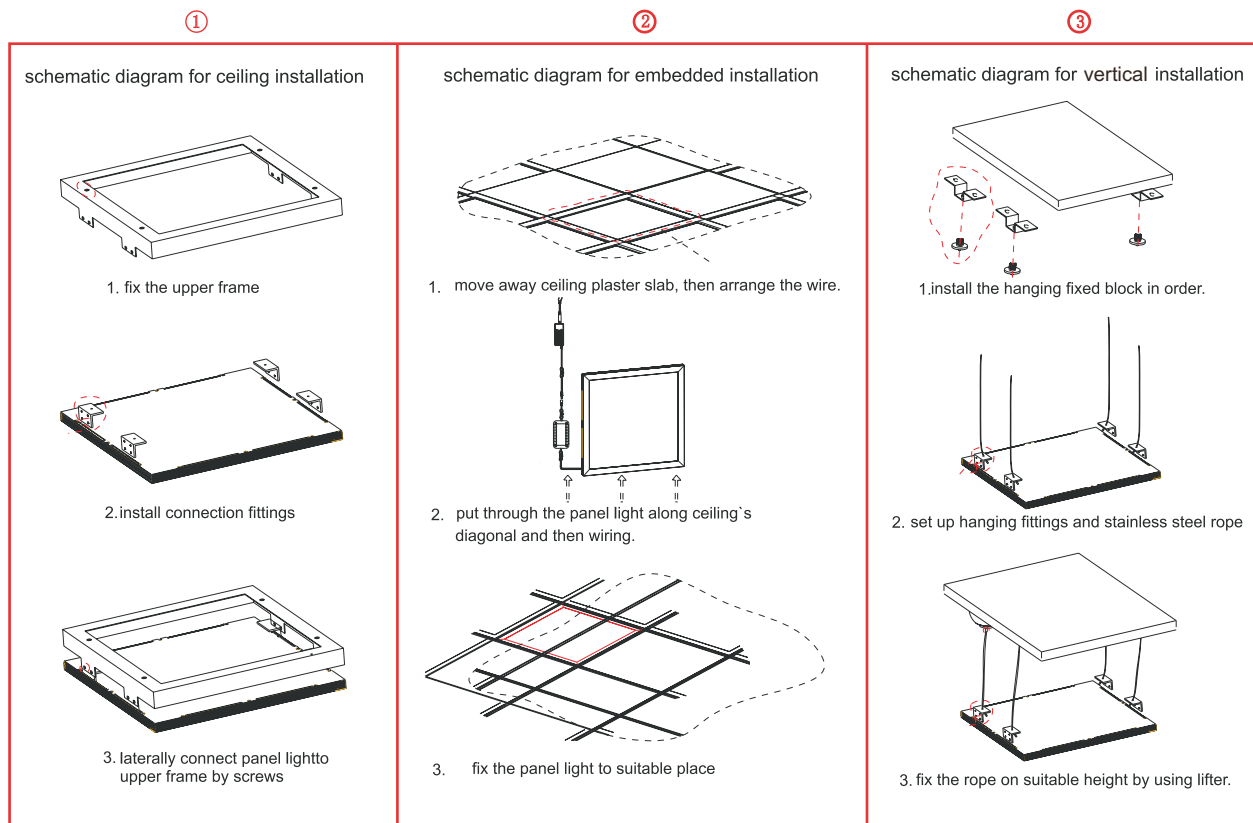
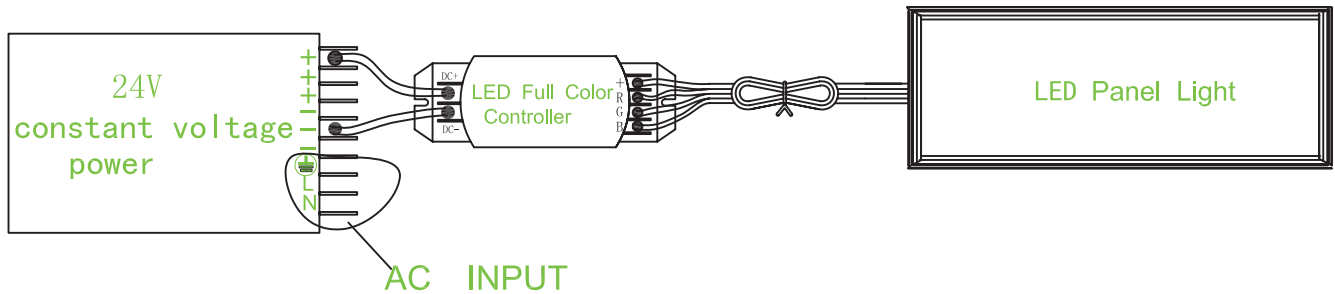

Install instruction:

1. turn off the power switch.
2. connect the input-terminal with utility power(AC 100-240V) by using wiring-unit, make certain that no copper wire is bared
3. connect the output-terminal DC plug of current driver with the lamp`s DC plug ,insure this connection secure.
4. fix the lamp and current driver to the suitable place by convenient installation.
5. turn on the power switch.

Signcomplex Limited Warranty

Signcomplex warrants this product ("Product") against defects in material or workmanship for a period of three years from the date of purchase. If this Product is determined to be defective, Signcomplex will repair or replace the Product, at its option. This warranty does not cover cosmetic damage or damage due to acts of God, accident, misuse, abuse, negligence, commercial use, or modification of, or to any part of the Product. This warranty does not cover damage due to improper operation or maintenance, connection to improper voltage supply, or attempted repair by anyone than a facility authorized by Signcomplex to service the Product.

Repair or replacement as provided under this warranty is the exclusive remedy of the customer. Signcomplex shall not be liable for any incidental or consequential damages for breach of any express or implied warranty on this Product except to the extent prohibited by applicable law, any implied warranty of merchantability or fitness for a particular purpose on this Product is limited in duration to the duration of this limited warranty.

Some states do not allow the exclusion or limitation of incidental or consequential damages, or allow limitations on how long an implied warranty lasts, so the above limitations or exclusions may not apply to you. This warranty gives you specific legal rights, and you may have other rights which vary from state to state.

Only Signcomplex may change, amend or modify the terms of this Limited Warranty and any such change, amendment or modification shall be in writing and is signed by Signcomplex. To obtain warranty service and shipping information call +86 755 2760 8650 or e-mail info@signcomplex.com. You must provide proof of purchase in the form of a bill of sale or receipted invoice which is evidence that the Product is within the warranty period to obtain warranty service. Consumers have legal rights under applicable national legislation governing the sale of consumer goods. Such rights are not affected by the warranties provision outlined in this document.